

EQ Wave™ v1

Continuous Point-on-Wave Power Quality Sensor

Datasheet

PRE-PRODUCTION

This datasheet covers EQ Wave v1 pilot hardware. The certified production version (v2) is in development. Contact Energy Quotient™ for v2 specifications and availability.

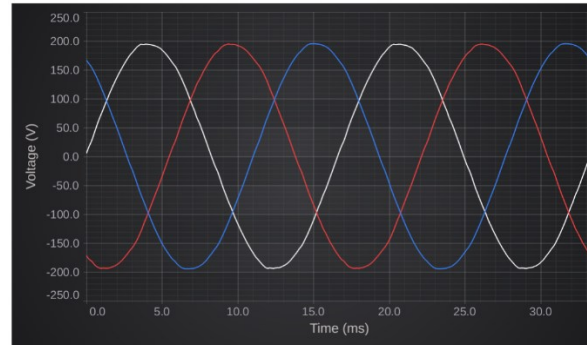

Description

EQ Wave v1 is a compact, high-resolution power quality sensor for continuous 3-phase voltage and 4-channel current measurement. It samples at 32 ksps, 24 bits per channel, and streams over optical fiber to an edge gateway. Unlike event-triggered power quality meters, EQ Wave provides uninterrupted point-on-wave data for forensic analysis, AI-driven diagnostics, and long-duration compliance monitoring.

The sensor is designed for safe, robust, permanent monitoring of industrial, commercial, and utility electrical equipment. Voltage measurement inputs and AC power input are galvanically isolated from the backend electronics, DC input, and current channels. Power is drawn from the measured circuit (85–528 V AC) or an auxiliary DC supply (4.5–36 V DC), with internal backup for clean capture through brief interruptions.

EQ Wave focuses on accurate, gapless measurement and embedded front-end metrics. Visualization, configuration, and deep analytics are delivered by a companion EQ Gateway, allowing the sensor and compute stack to be fully adapted to the application.

Features

- 32 ksps, 24 bits per channel, 7-channel simultaneous-sampling $\Delta\Sigma$ ADC
- 3-phase voltage input up to 600 V RMS; 4 current channels
- Fully differential current inputs for common-mode noise rejection and ground-loop immunity
- Two-stage isolation: 3 kV internal barrier and optical comms
- Dual TCP streams over 100Base-FX (optical): power metrics and waveforms
- -40 °C to +70 °C industrial operating range (fanless, no moving parts)
- Flexible mounting: screw-through flanges, reclosable fastener, or DIN rail

Applications

- Semiconductor fab yield protection and tool health
- Medical imaging and diagnostic equipment power QA
- Microgrid and DER interconnection and transient analysis
- Advanced manufacturing preventive maintenance and compliance
- Critical-infrastructure and defense power resilience
- Utility feeder and substation disturbance recording

Functional Block Diagram

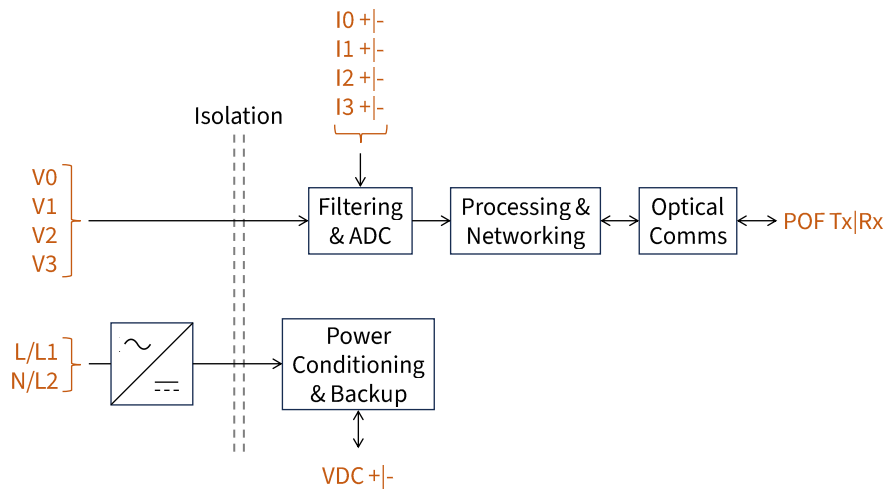

Ordering Information

Part Number	Description
EQW1	EQ Wave v1, includes POF interface kit

Append the following optional suffixes:

- -R — configured for Rogowski coils instead of voltage-output current transducers
- -B1 — internal burden resistors populated for 1 A current transformer secondaries
- -DIN — DIN rail backplate installed (35 mm rail per IEC 60715)

-R and -B1 are mutually exclusive. Contact Energy Quotient for non-standard current input configurations.

Accessories

Part Number	Description
EQW1-ACC-MAG	Magnet mount kit for flat ferrous surfaces, customer-installable
EQW1-ACC-DIN-KIT	DIN rail backplate replacement kit (requires backplate swap)
EQW1-ACC-POF-KIT	POF interface kit: cutting tool, media converter, 1 m patch cable
EQW1-ACC-POF-□M	2.2 mm duplex POF cable, sold by the meter (□ = meters)

Specifications

Voltage Input

Parameter	Conditions	Min	Typ	Max	Unit
Input impedance	Vx to V0	—	4	—	MΩ
Measurement accuracy ¹	25 °C	—	±0.18	—	% of reading
Thermal drift ¹	-40 to +70 °C	—	—	±70	ppm/K
Frequency range	—	45	—	65	Hz

Input Range Settings

Range	Measurement Range (Vx to V0)	Absolute Max	Typical Systems
1	up to 600 V RMS	944 V RMS	600 V / 480 V Delta
2	up to 300 V RMS	472 V RMS	480/277 V Wye, 600/346 V Wye, 240 V
3	up to 150 V RMS	236 V RMS	240/120 V split-phase

Range is configured at the factory based on the target service; contact Energy Quotient for non-default configurations. Absolute max values reflect front-end saturation limits; sustained operation above the measurement range degrades accuracy and may eventually damage the input stage.

Current Input

Parameter	Conditions	Min	Typ	Max	Unit
Input impedance, differential	Ix+ to Ix-	—	136	—	kΩ
Input impedance, common-mode	Each terminal to DC ground	—	68	—	kΩ
Measurement accuracy ¹	Excl. external sensor error	—	±0.14	—	% of reading
Thermal drift ¹	-40 to +70 °C	—	—	±35	ppm/K

Compatible with voltage-output current transducers (e.g., Socomec Accu[®]-CT 333 mV split-core sensors), 1 A secondary CTs, and 100 mV/A Rogowski coils. Contact Energy Quotient for non-default sensor configurations.

¹ Pre-calibration value.

Data Acquisition

24-bit delta-sigma ADC, 32 kpsps simultaneous sampling across 3 V + 4 I channels.

Parameter	Conditions	Min	Typ	Max	Unit
Signal-to-noise ratio	—	—	101	—	dB
Effective number of bits	Derived from SNR	—	16.5	—	bit
Sensor latency	ADC-to-wire	—	4	—	ms
End-to-end latency	To gateway, low-loss link	—	8	—	ms

Power Supply

EQ Wave is powered by either AC or DC input, not both. When powered from AC, the DC port becomes a 12 VDC auxiliary output for powering downstream devices (up to 1.6 W).

Parameter	Conditions	Min	Typ	Max	Unit
AC input voltage	Via voltage connector, L-N or L-L	85	—	528	V AC
AC input protection	Slow-blow fuse	—	2	—	A
DC input voltage	Via DC port, when AC not connected	4.5	—	36	V DC
Power consumption	AC-powered	—	3.3	—	W
Power consumption	DC-powered	—	2.4	—	W
Additional load per phase	277 V L-N	—	19	—	mW
DC aux output voltage	At DC port, when AC-powered	—	12	—	V DC
DC aux output power	—	—	—	1.6	W
Backup hold-up time	—	—	8	—	s

Isolation and Withstand Ratings

Full galvanic isolation between the voltage inputs + AC supply and the backend electronics, DC input, and current channels. Two-stage measurement isolation path: internal capacitive barrier + fiber optic network.

Item	Value / Description
Voltage isolation to ground	3 kV RMS, 1-minute withstand
Insulation resistance	> 1 GΩ

Full galvanic isolation allows V0 to be referenced as neutral, earth-bonded, or left floating at line potential, providing installation flexibility across grounded and ungrounded systems while maintaining safety and measurement integrity.

Communications

Item	Value / Description
Physical layer	100Base-FX
Media	2.2 mm duplex plastic optical fiber
Connector	Firecomms OptoLock®
Protocol	TCP/IP
Waveform port	1534 — continuous waveform stream, 2 ms intervals
Metrics port	1535 — power system and power quality metrics, 10/12 cycle updates
IP configuration	Fixed 192.168.10.10 (v1 firmware)
Time sync	IEEE 1588 PTP hardware-capable

Reported power metrics: RMS voltage and current (per phase), active/reactive/apparent power, power factor, displacement power factor, frequency, total harmonic distortion, individual harmonics, voltage and current unbalance, peak voltage and current. Fundamental voltage, current, and power are provided in addition to their totals. Metric set is expandable upon request.

Environmental and Mechanical

Item	Value / Description
Operating temperature	-40 to +70 °C, ambient
Expected service life	10 years at 70 °C ambient
Enclosure material	Black polycarbonate, UL94-V0, UV-stabilized
Dimensions (W × D)	180 × 91 mm (7.07 × 3.57 in), enclosure footprint incl. flanges
Height, without mated connectors	46 mm (1.81 in)
Height, with mated connectors	69 mm (2.72 in)
Mounting	Screw-through flanges, 3M Dual Lock reclosable fastener, or 35 mm DIN rail (IEC 60715)
Cooling	Fanless, natural convection
Weight	266 g

Standards and Compliance

Designed to IEC 61010-1 CAT III, pollution degree 3. UL 1059 Group C and Group D voltage ratings apply as noted in the voltage input specifications. Formal certification is planned for EQ Wave v2; v1 is pre-certification pilot hardware and should not be specified in safety-critical applications.

Terminal Designations

Terminal	Function	Notes
Voltage connector		
L / L1	AC supply line 1	—
N / L2	AC supply neutral or line 2	—
V0	Voltage reference (neutral or line, per topology)	—
V1	Voltage input, phase 1	—
V2	Voltage input, phase 2	—
V3	Voltage input, phase 3	—
Current connector		
I0+ / I0-	Current channel 0, differential	—
I1+ / I1-	Current channel 1, differential	—
I2+ / I2-	Current channel 2, differential	—
I3+ / I3-	Current channel 3, differential	—
VDC+	DC input or 12 V DC aux output	Input when AC not connected; output when AC-powered
VDC-	DC return	Connect to ground for best noise performance
POF connector		
Tx / Rx	Optical fiber transmit / receive	Firecomms OptoLock®

Typical Connection Diagrams

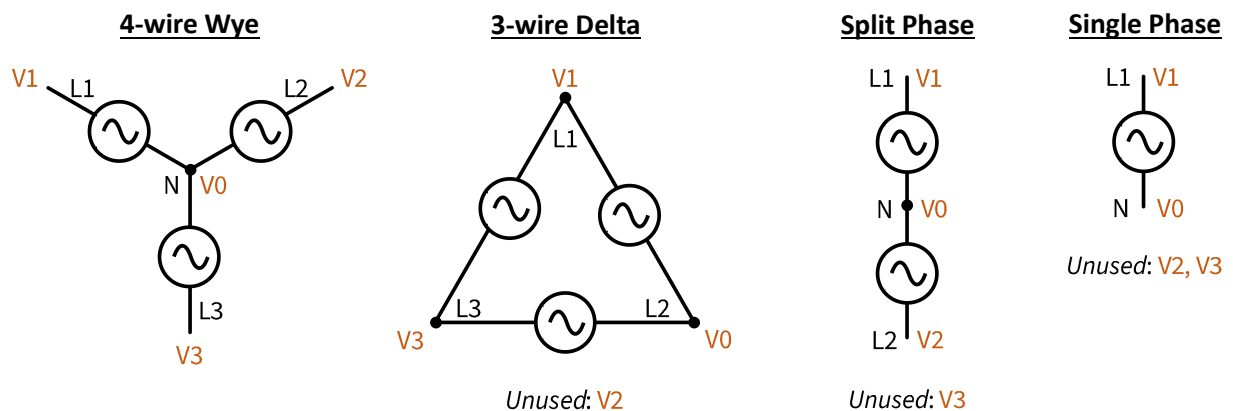

Mating Connectors

Connector	Weidmüller P/N	Poles × Pitch	Wire Range
Voltage	8000078357	6 × 7.50 mm	AWG 20–12 (0.5–4 mm ²)
Current	2741750000	10 × 5.00 mm	AWG 20–12 (0.5–4 mm ²)

A pair of mating connectors ships with each EQ Wave v1 unit. Part numbers are listed for reference when additional or replacement connectors are needed. Both are Weidmüller OMNIMATE® 4.0 female connectors with tool-free, snap-in termination, accepting solid or stranded wire with or without ferrules. Voltage connector rated 600 V UL / 1000 V IEC.

Mechanical Drawing

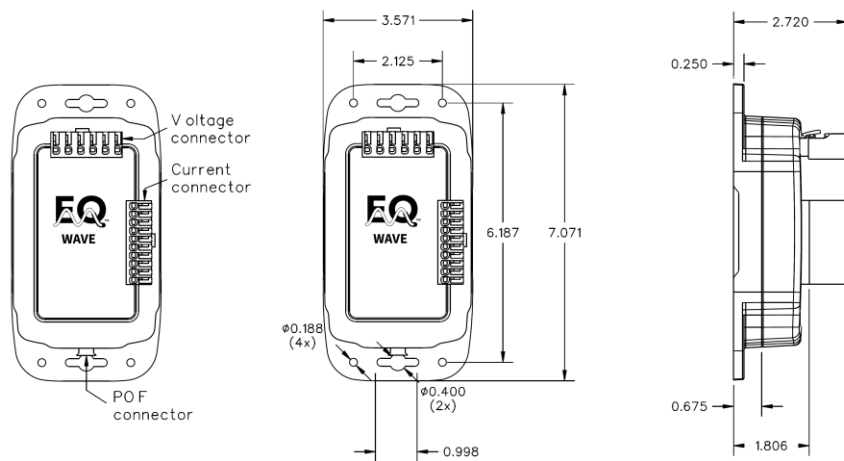

All dimensions in inches (± 0.015)

Software and Data Access

EQ Wave provides two data streams: continuous point-on-wave waveforms (CPOW, port 1534) and power metrics (port 1535). EQ offers a layered software stack that ingests, stores, visualizes, and analyzes this data, deployable on EQ Gateway hardware or customer-supplied Linux.

equser — Open-Source Python Library

Suitable for integrating power metrics with existing SCADA, data historians, custom dashboards, or research workflows. Python's performance is not sufficient to capture gapless CPOW; EQ Coherence is required.

pypi.org/project/equser | equser.eq.systems

EQ Coherence

Captures and stores CPOW and power metrics into a Parquet data lake (a month or more of gapless CPOW history, depending on storage). Web-based visualization for live and historical data. Data API for downstream integration. Runs on EQ Gateway hardware or customer-supplied Linux.

EQ Syntropy

Turns CPOW data into actionable engineering insight at the fleet scale using an EQ-developed Cyber-Physical AI system — grounded analyses backed by physics-based and signal-derived models. Continuously extracts engineering features, runs analyses, and assembles results into a facility-wide knowledge graph with standards compliance context. Runs on GPU-equipped edge hardware or EQ-managed servers.

Production Hardware (v2)

EQ Wave v2 is the certified production version of the platform, currently in development. It introduces advanced onboard processing, expanded memory and onboard storage, over-the-network firmware updates, and formal safety and EMC certification.

Contact Energy Quotient for v2 specifications, availability, and pilot-to-production migration planning:

info@eq.systems | eq.systems

Energy Quotient™ and EQ Wave™ are trademarks of EQ Systems Inc. Specifications are subject to change.